

Front Side Door Sill Trim Plate Package Installation (Instruction ID: 84359690)

Installation Instructions Part Number

84359690

Note: Please review the entire procedure before trying to perform it.

Kit Contents

Qty	Description
2	Illuminated Sill Plate Assembly
1	Wiring Harness Pkg (Contains Harness ASM (QTY 1) and Wire Tie Straps (QTY 8))

Recommended Tools

- Drill, 19 mm, (3/4") drill bit
- Flat Bladed Plastic Trim Tool
- 2mm Width Flat Screwdriver
- 0.8mm Width Flat Screwdriver
- Push-in Retainer Puller
- Electrical Tape
- 10mm Socket
- Trim Removal Tools
- Small Ratchet
- Wire Puller
- Heat Gun
- Wire Crimp Tool
- Magnet and / or Vacuum

Procedure

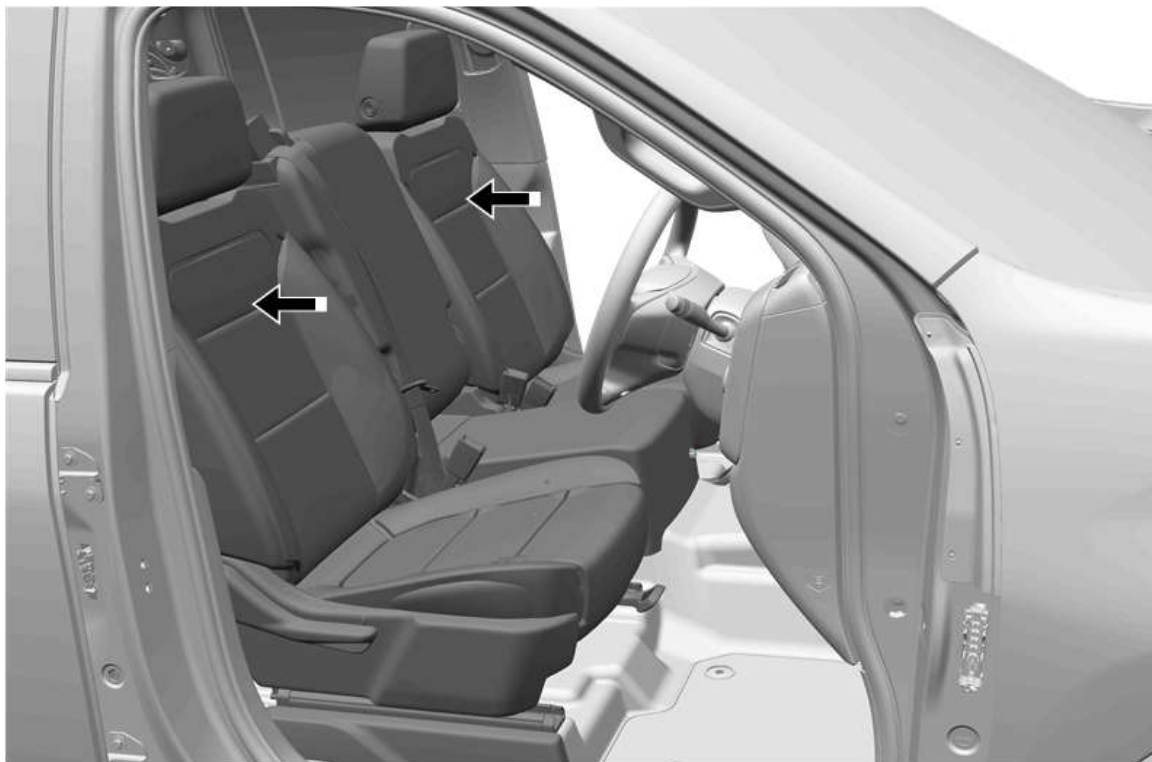

1. Move the front seats to the furthest rearward position.

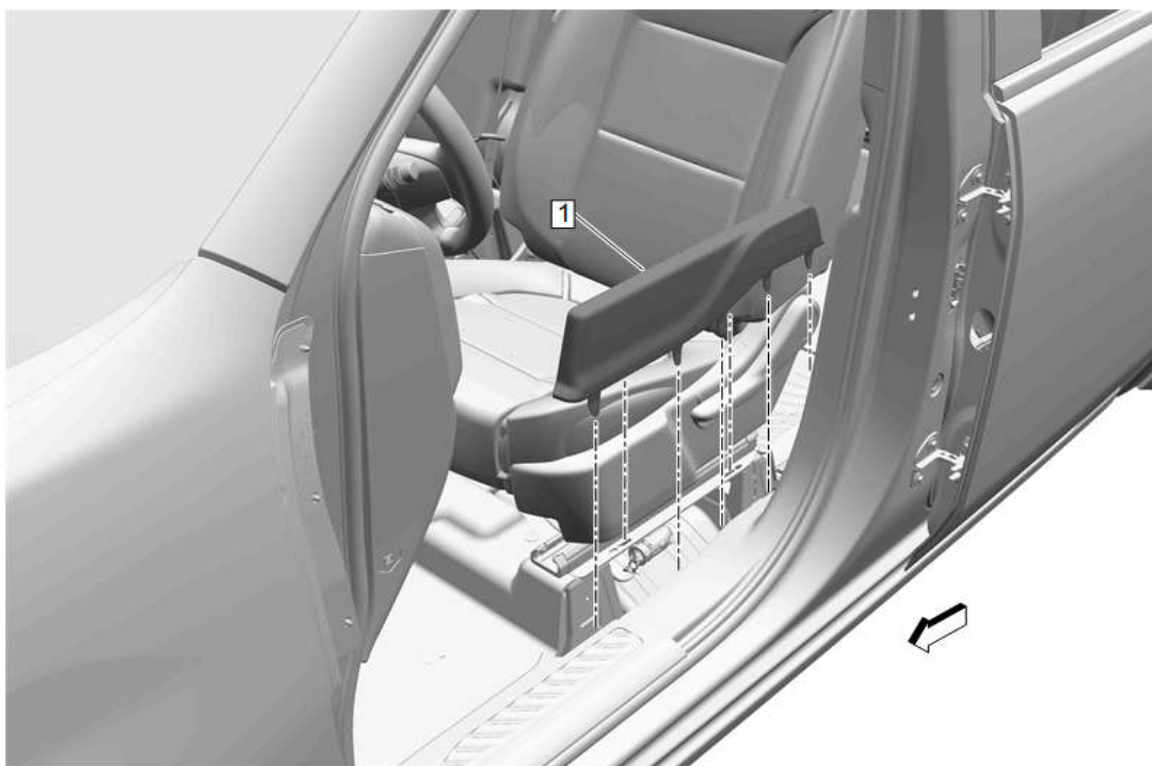

2. Pull upward and remove the front seat adjuster track finish cover (1).



3. Starting at the rear of the garnish molding, pull upward at the B-pillar joint to release the up/down clips first.
4. Rotate the sill garnish molding (1) inboard after releasing up/down clips and pull rearward to disengage the two clips on the forward vertical wall.

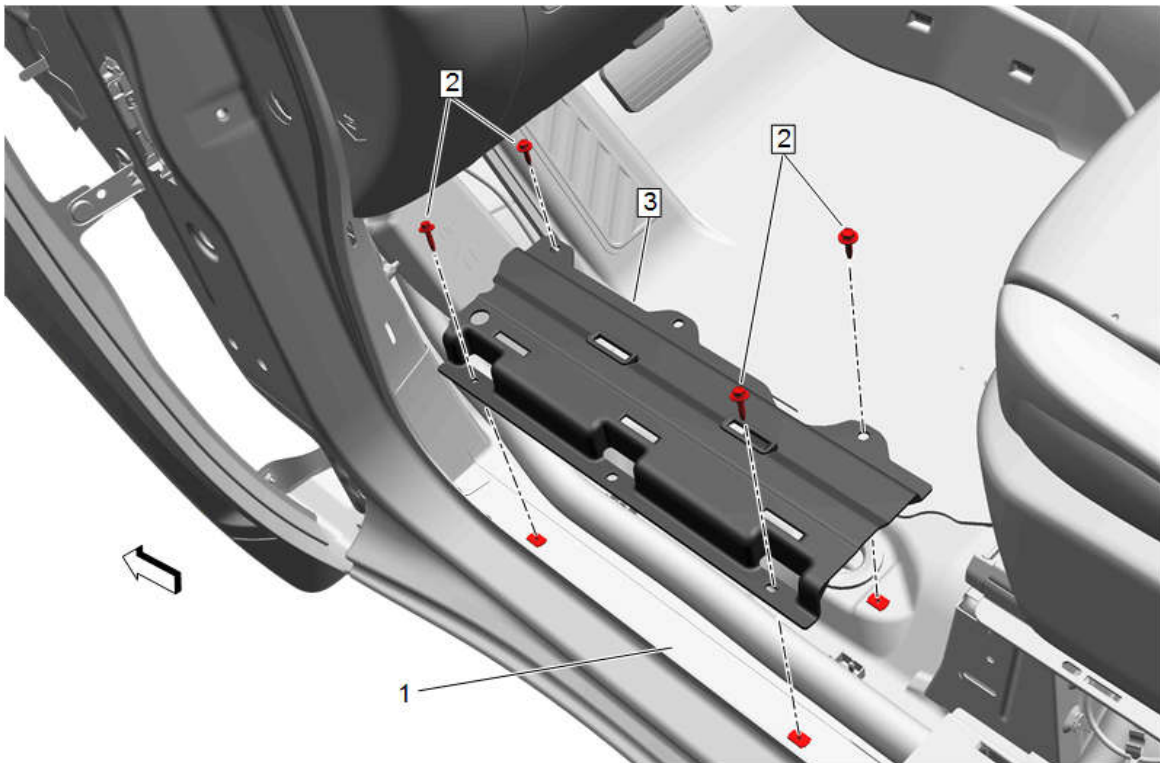

5. Remove the screws (2) from the harness sill protector (3).
- © 2020 General Motors. All rights reserved.

6. Remove the harness sill protector (3) from rocker panel (1).

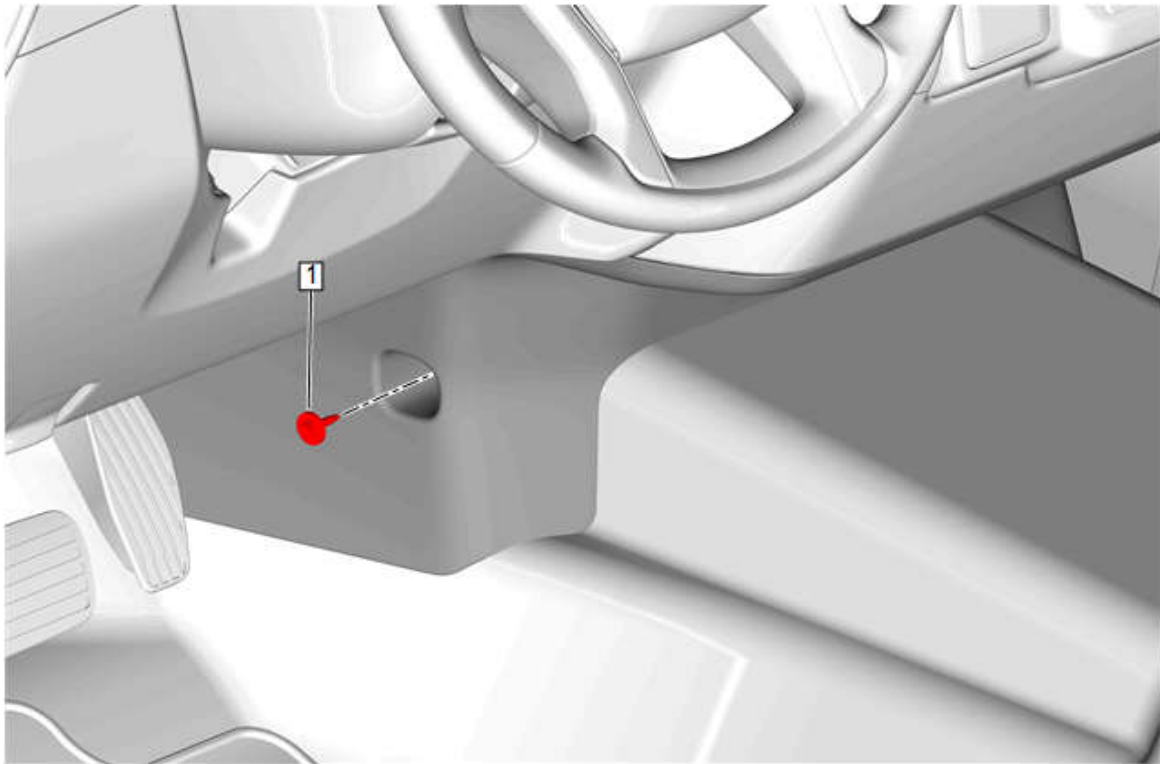

7. Remove the bolt (1) from each side of the instrument panel lower center trim panel. Upon reassembly tighten the bolt to 2.5 N.m (22 lb in).

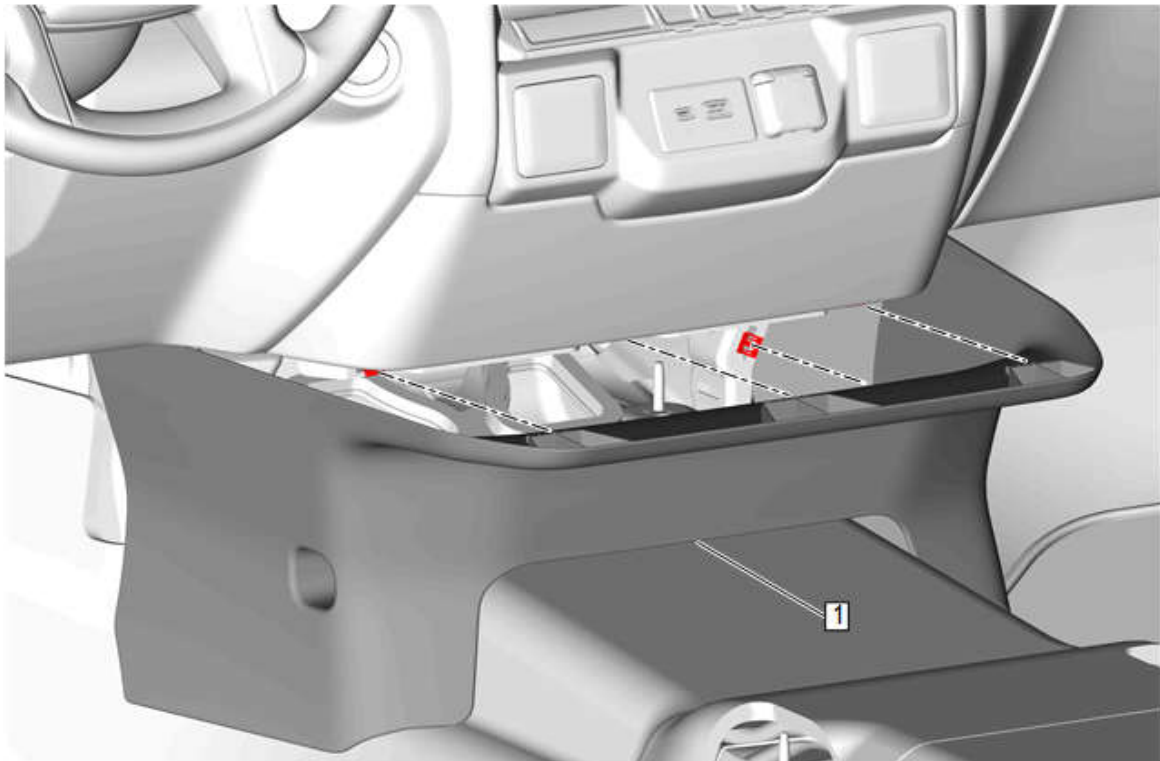

8. Remove the instrument panel lower center trim panel (1) from lower instrument panel.

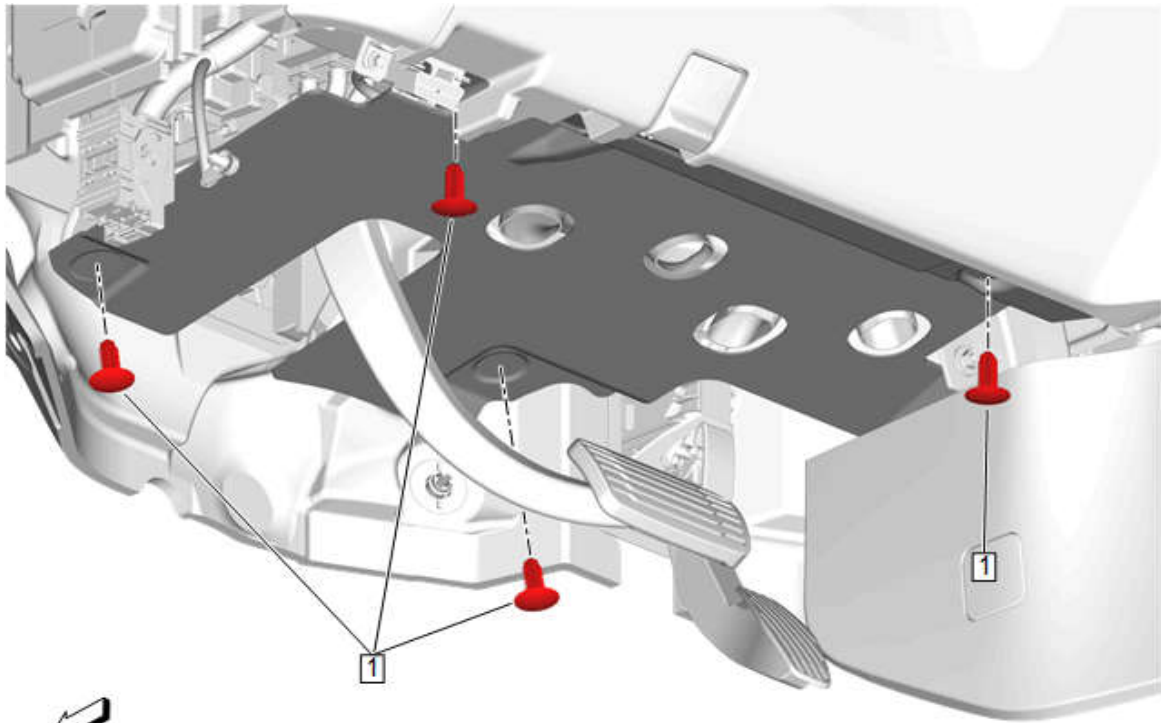

9. Remove the retainers (1) from the instrument panel lower insulator.

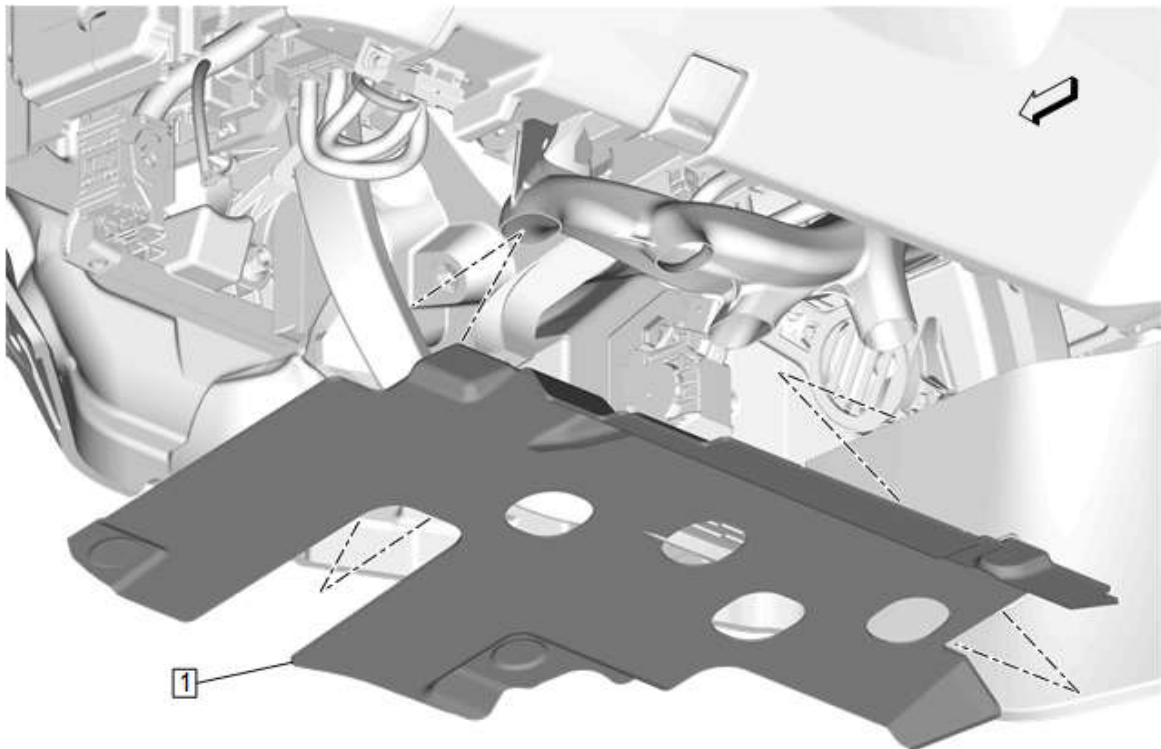

10. Remove the instrument panel lower insulator (1) from lower instrument panel.

11. Remove front floor mats and reposition front carpet as necessary.

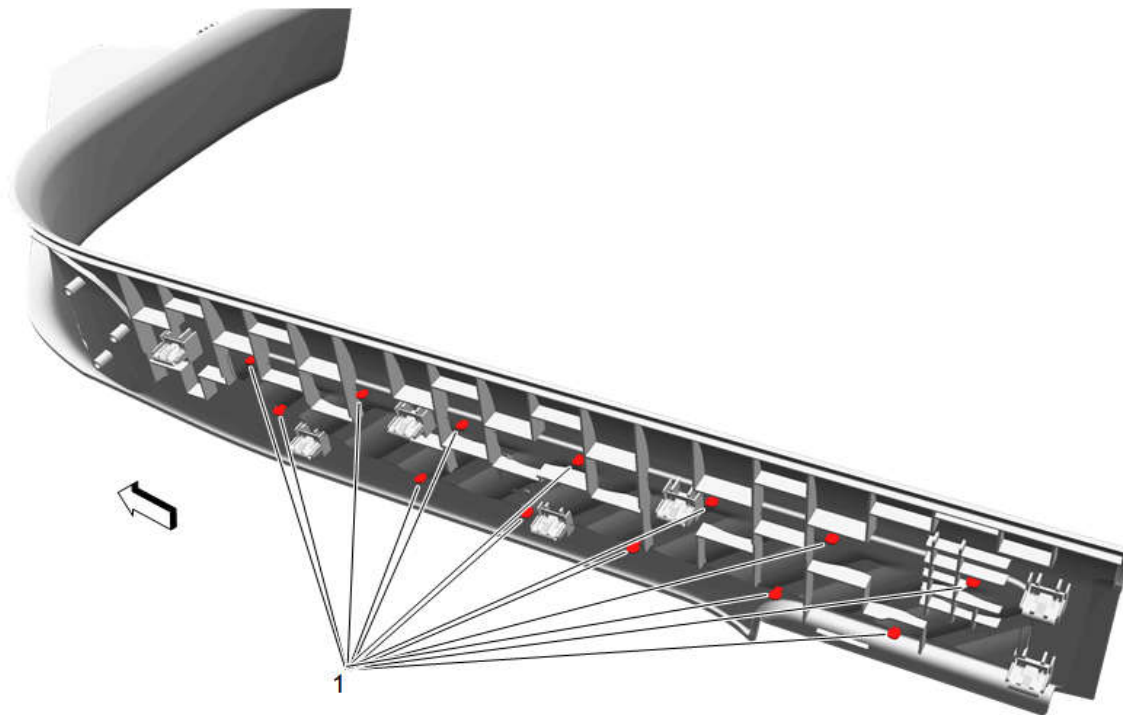

12. Disengage the sill center tabs (1) on the back side of the sill garnish molding.

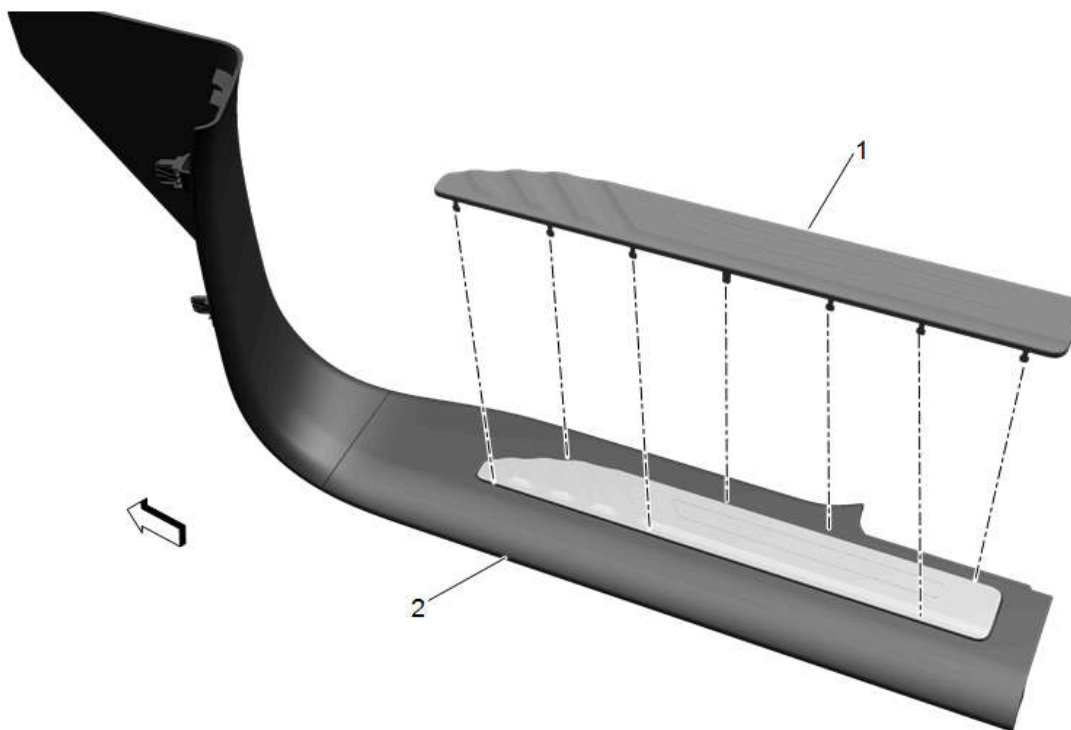

13. Remove the sill center (1) from the sill garnish molding (2).

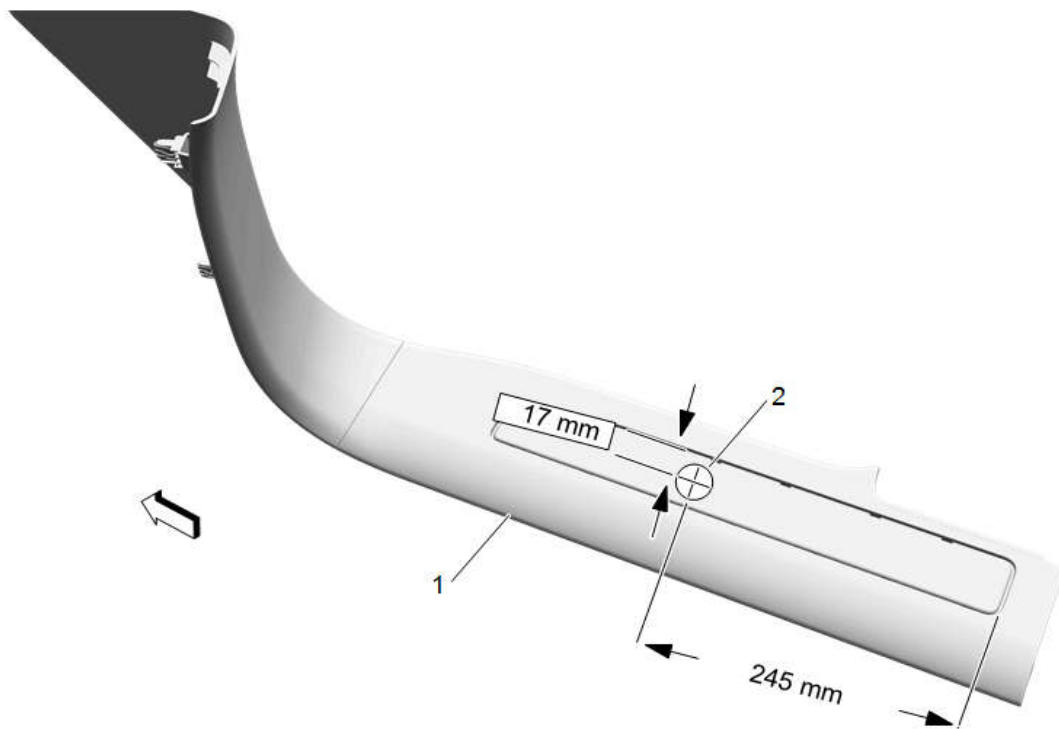

Note: Always check scale, size and position of all holes before drilling. Failing to do so may cause damage to the vehicle, misalignment of components or the inability to install the accessory.

- 14. Drill a 19 mm (3/4") hole (2) into the sill garnish molding (1) according to the dimensions shown.

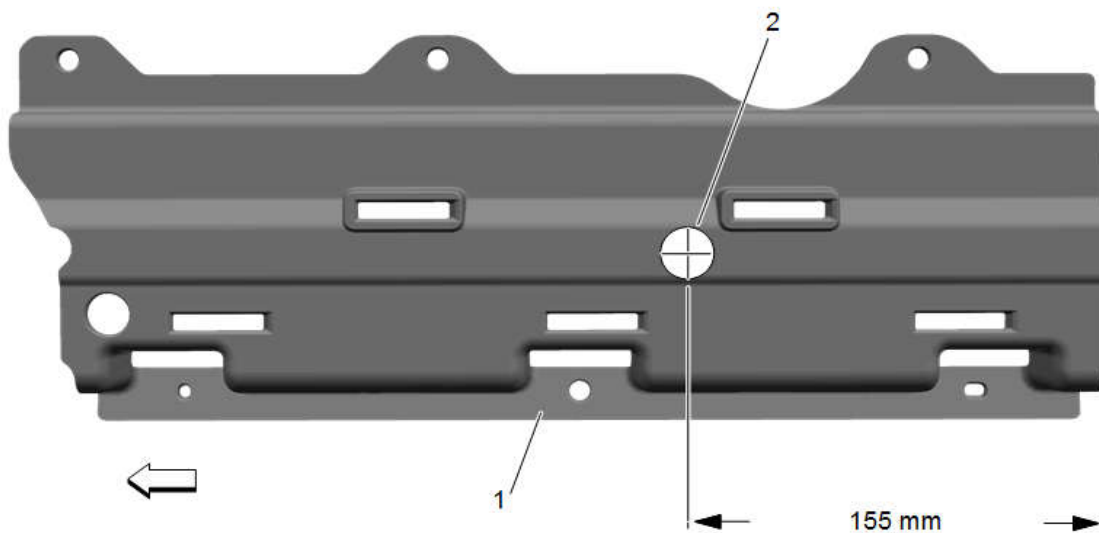

15. Drill a 19 mm (3/4") hole (2) into the harness sill protector (1) according to the dimensions shown.

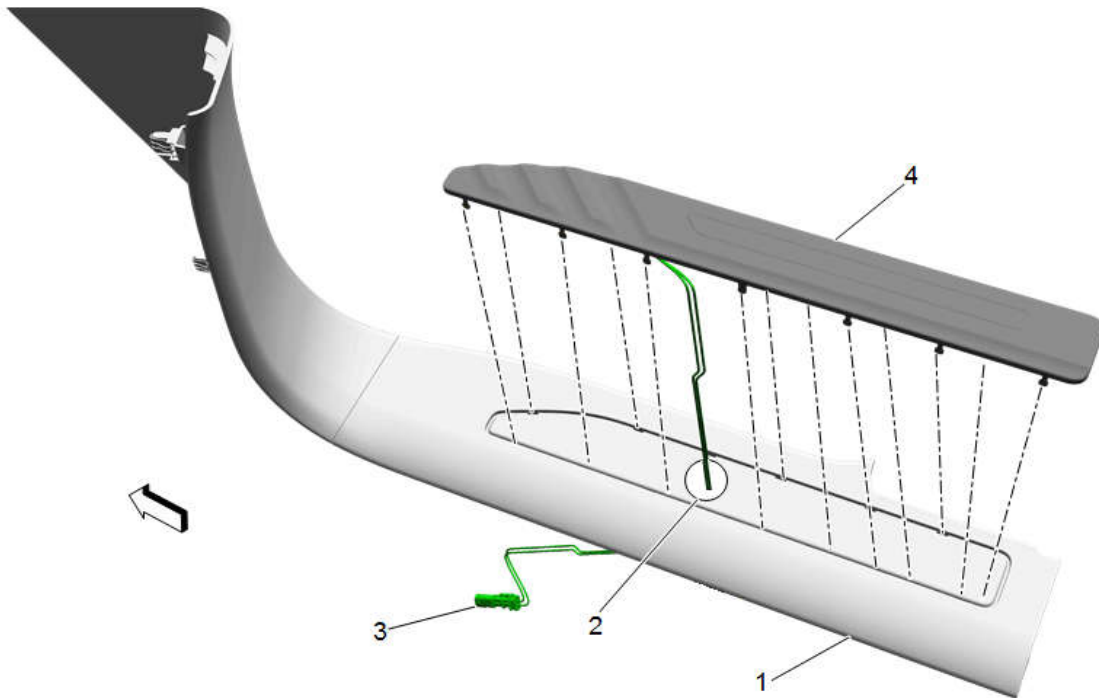

16. Insert the electrical connector (3) of the illuminated sill (4) through the previously drilled hole (2) in the sill garnish molding (1).
17. Pull harness through and install the illuminated sill (4) to the sill garnish molding (1) engaging the center tabs on the under side of sill garnish molding.



18. Route wiring harness through the vehicle as shown.

18.1. Begin by spreading out the harness to understand how it is routed through the vehicle. The harness will route from the driver side, to the passenger side, near the top edge of the carpet. The ground eyelet attaches in the passenger side cowl and the two loose wires attach to the BCM harness under the driver side of I/P.

18.2. 2. Route the harness (1) loosely across the dash panel near the top of the carpet with the BCM connections on driver side under I/P, and ground (2) on the right side.

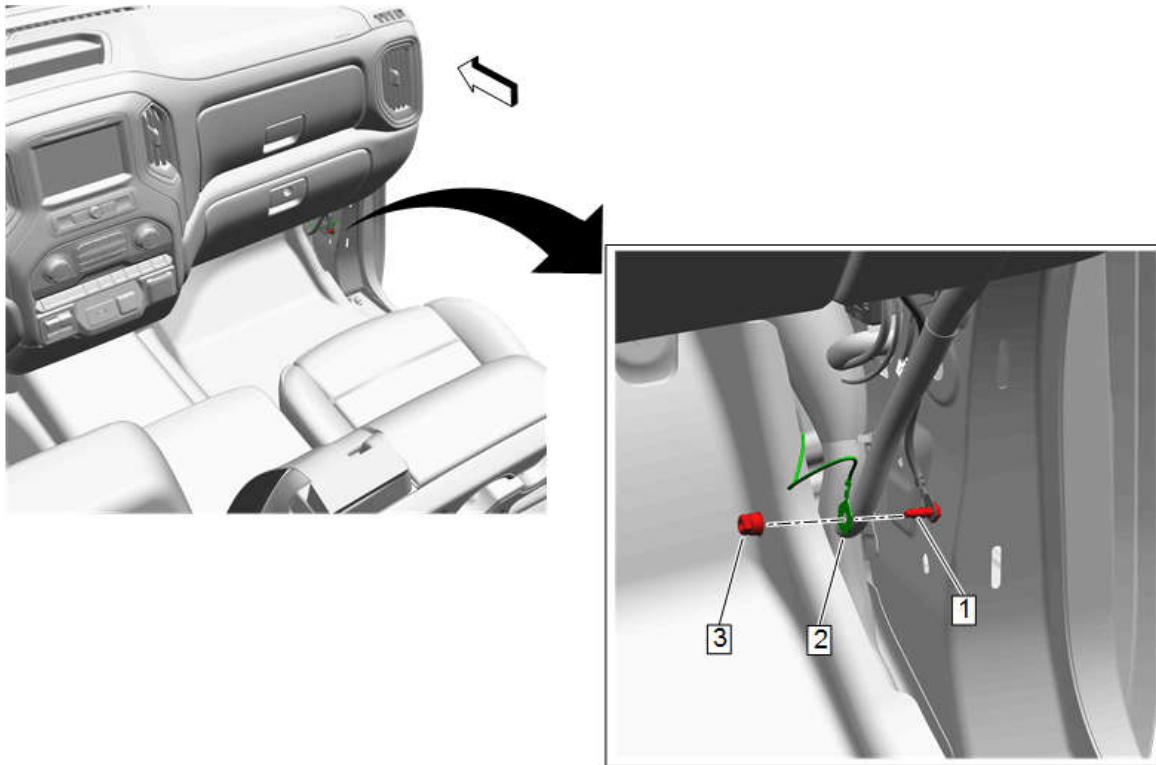

19. Locate the ground stud (1) on the passenger side cowl. If equipped with more than one stud, choose the stud with only one eyelet.
20. Remove the ground nut (3) and install the illuminated sill plate harness ground eyelet (2) to the ground stud (1).

Caution: Use the correct fastener in the correct location. Replacement fasteners must be the correct part number for that application. Fasteners requiring replacement or fasteners requiring the use of thread locking compound or sealant are identified in the service procedure. Do not use paints, lubricants, or corrosion inhibitors on fasteners or fastener joint surfaces unless specified. These coatings affect fastener torque and joint clamping force and may damage the fastener. Use the correct tightening sequence and specifications when installing fasteners in order to avoid damage to parts and systems.

21. Reinstall the ground nut (3) and tighten to 25 N.m (18 lb in).

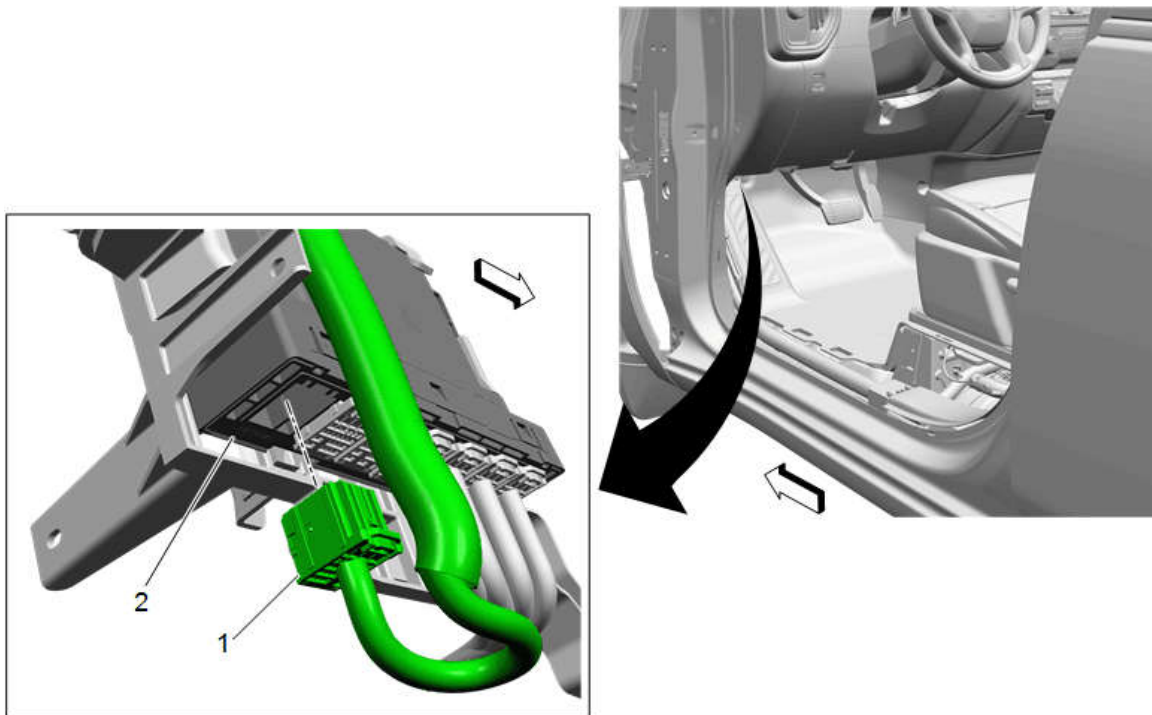

- 22. Locate the BCM (2) on the driver side of the vehicle, under the I/P. Disconnect BCM connector (1) X1 Natural.

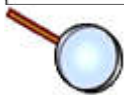
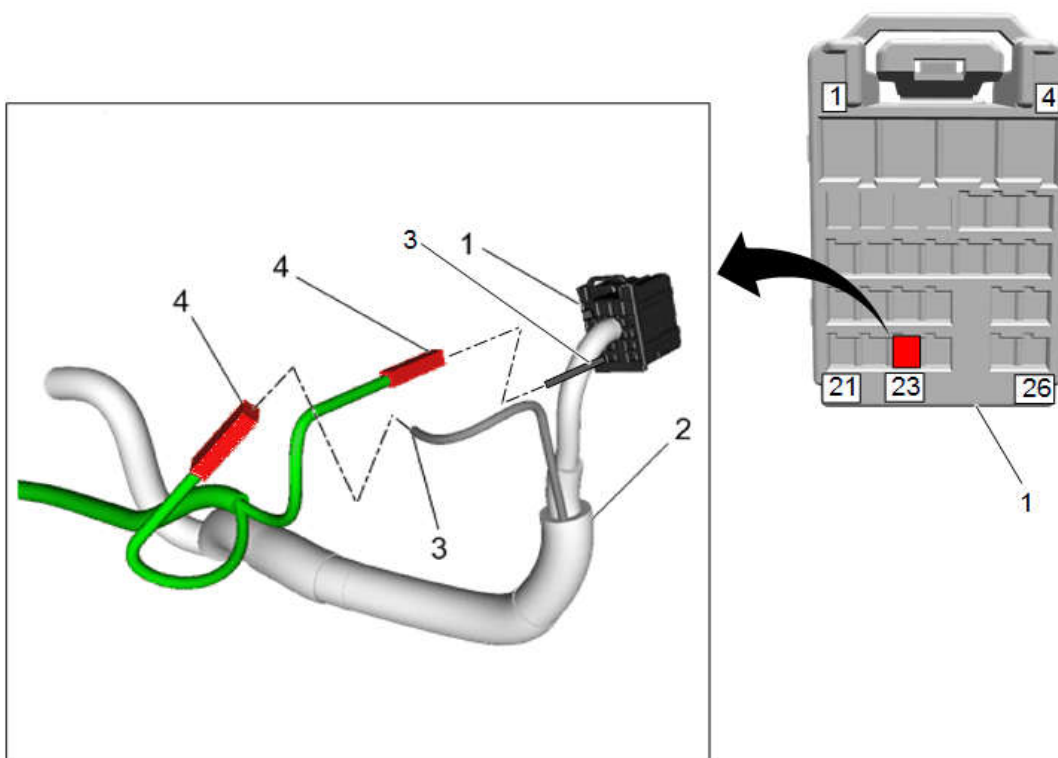

Important: DO NOT remove the terminal from cavity #23 in the following step.

- 23. Locate cavity #23 on the removed connector (1). Remove wire harness covering (2) starting from connector for approximately 4".

24. Gently separate the wire (3) leading to cavity #23 from the rest of wire bundle.
25. Approximately 50 mm from the rear of the connector cut the wire (3) leading to cavity #23.
26. On the supplied wire harness locate 2 blunt (unterminated) ends routed near BCM. Using recommended service technique and the supplied crimp splices (4) splice 1 blunt end to each side of the cut wire (3).
27. Seal splices and re-tape harness to within 25 mm of rear of connector.

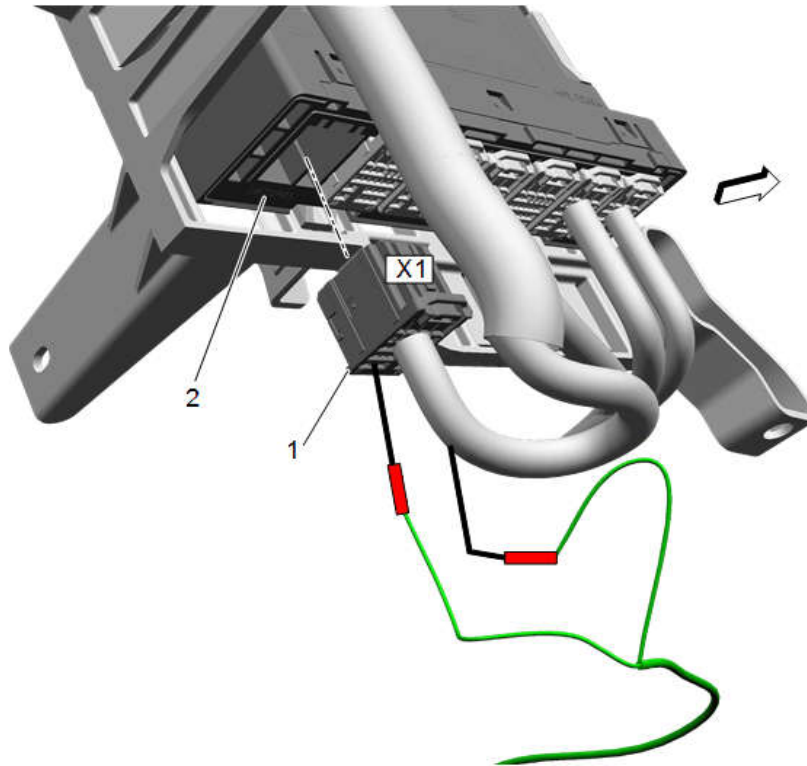

28. Re-connect connector X1 (1) to the BCM (2).

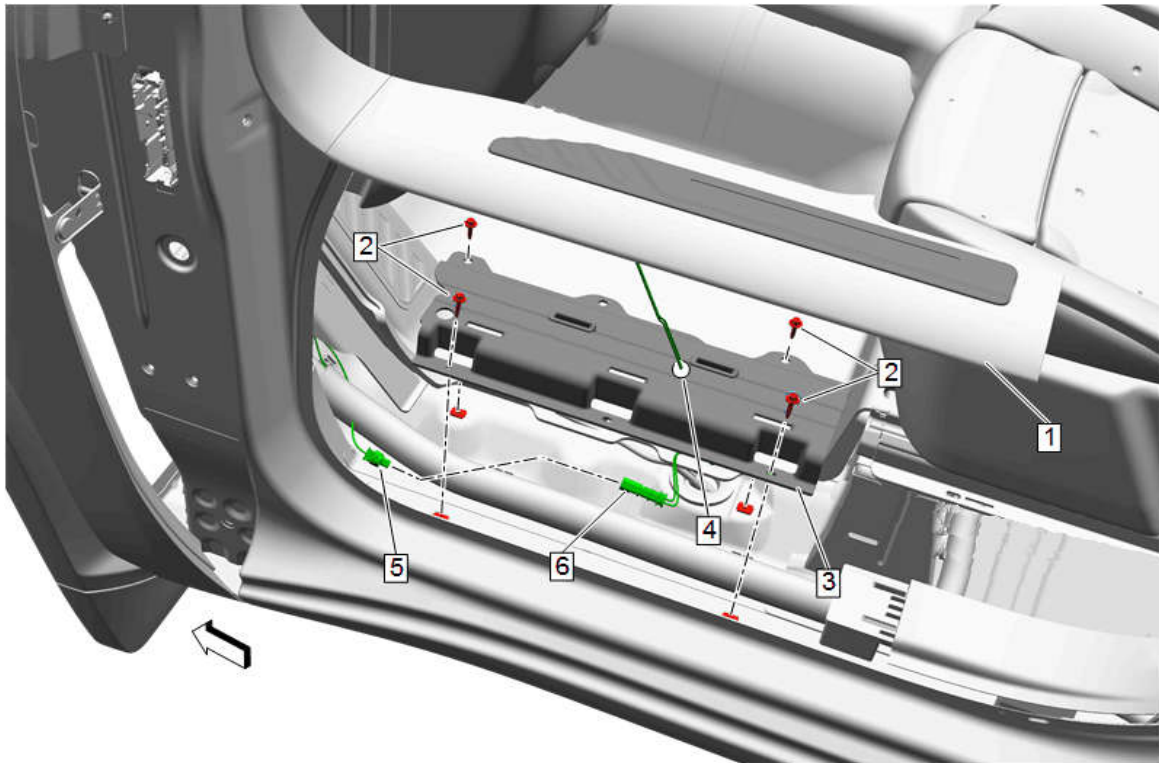

29. Insert the electrical connector (6) of the illuminated sill garnish molding (1) through the previously drilled hole (4) in the harness sill protector (3).
30. Plug in the electrical connector (6) of the illuminated sill garnish molding to the illuminated sill wire harness (5). Do not fully install the harness sill protector and illuminated sill garnish molding at this time.

Check Operation of the Illuminated Sill Plates

- 30.1. Verify all disconnected electrical connections are re-connected.
- 30.2. Close all doors
- 30.3. Open each door, door garnish molding will illuminate when the dome light illuminates.
- 30.4. The door sill garnish molding should light up and go out with dome lamp (make sure dome lamp is on).
- 30.5. If the sill garnish molding does not light up, check the ground and BCM splice as well as other connections at illuminated sill garnish moldings, (make sure dome lamp switch is not in defeat position).
- 30.6. Check to see if the courtesy lights are working.
- 30.7. Verify that the illuminated sill garnish moldings are operating correctly.
- 30.8. Pull back the carpet and route the harness along the floor about 50 to 75 mm below the top of the carpet, from side to side.
- 30.9. Use tie straps, as required, to keep harness secure and from being seen. 8 tie straps are provided in the harness package.
- 30.10. Secure the sill harness protector (3) to the rocker panel with the previously removed screws (2). Tighten screws to 2.5 N.m (22 lb in).
- Note:** The illuminated sill plates can be installed on either side of the vehicle.
- 30.11. Align the illuminated sill garnish molding snap features to the holes on the sill harness protector and forward vertical wall.
- 30.12. Firmly press into place until the illuminated sill garnish molding (1) is fully seated.
- 30.13. Repeat for the second illuminated sill plate on the opposite side of the vehicle.

Re-install Carpet and Trim

1. Check clips on removed trim panels, replace clips if necessary.
2. Tuck wire harness behind carpet and trim.
3. Reposition carpet, and reinstall removed trim panels.

Note: Verify all wires are neatly secured, not pinched and not visible, tie straps should be used as necessary to keep harness secured and out of sight.