

Service Connector: Service by Harness - See Part Catalog  
 Description: 2-Way F 1.0 Series (PK with YE Cover)

**Terminal Part Information**

Terminal Type ID	Terminated Lead	Diagnostic Test Probe	Terminal Removal Tool	Service Terminal	Tray Name	Core Crimp	Insulation Crimp
I	Not Required	No Tool Required	No Tool Required	Not Required	Not Required	Not Required	Not Required

**F106D Seat Side Air Bag - Driver (A2S)**

Pin	Size	Color	Circuit	Function	Terminal Type ID	Option
1	0.5	OG/BU	3068	Driver Side Impact Module High Control	I	—
2	0.5	BK/OG	3069	Driver Side Impact Module Low Control	I	—

**F106D Seat Side Air Bag - Driver (A2X)**

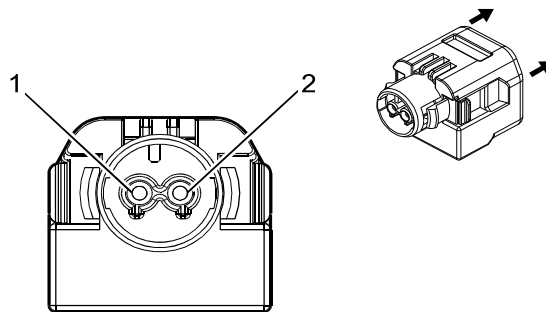

4772226

**Connector Part Information**

Harness Type: Driver Seat  
 OEM Connector: 1801935-1  
 Service Connector: Service by Harness - See Part Catalog  
 Description: 2-Way F 1.0 Series (PK with YE Cover)

**Terminal Part Information**

Terminal Type ID	Terminated Lead	Diagnostic Test Probe	Terminal Removal Tool	Service Terminal	Tray Name	Core Crimp	Insulation Crimp
I	Not Required	No Tool Required	No Tool Required	Not Required	Not Required	Not Required	Not Required

**F106D Seat Side Air Bag - Driver (A2X)**

Pin	Size	Color	Circuit	Function	Terminal Type ID	Option
1	0.5	OG/BU	3068	Driver Side Impact Module High Control	I	—
2	0.5	BK/OG	3069	Driver Side Impact Module Low Control	I	—