

Frame Cushion or Insulator Replacement Regular Cab

[Removal Procedure](#)

Important

Ensure that the vehicle is unloaded prior to body removal.

1. Remove the master cylinder. Perform the following steps:
 - A. Remove the nuts retaining the master cylinder to the brake booster.
 - B. Remove the master cylinder from the brake booster.
 - C. Secure the cylinder away from the booster.
2. Raise the vehicle on the hoist. Refer to [Lifting and Jacking the Vehicle](#) in General Information.
3. Remove the park brake equalizer intermediate cable. Perform the following steps:
 - A. Remove the nut from the park brake equalizer intermediate cable.
 - B. Remove the intermediate cable from the equalizer.
 - C. Depress the retaining tabs that secure the park brake cable to the frame.
 - D. Pull slightly on the cable from the mounting area in order to provide slack for body movement without binding the cable.

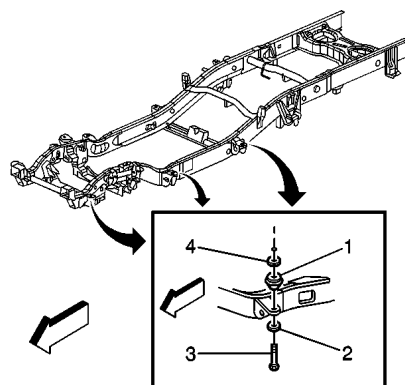

4. Remove the body mount bolts.
5. Properly support the body in the area that the mounts will be replaced.

Caution

When you remove the body cushions, do NOT separate the frame from the body more than is necessary. Possible personal injury and damage to multiple parts may result if you do not follow the guides outlined below:

1. **Intermediate steering shaft--Do not allow the shaft to extend more than 25 mm (1 in).**
 2. **Fuel tank filler hose--Do not stretch the hose excessively.**
 3. **Tail/Turn signal lamp wiring/rear lamps junction block--Leave slack in the wires.**
 4. **Park brake cable--Leave slack in the cable.**
 5. **Body ground straps--Leave slack in the wire.**
6. Lower the chassis accordingly in order to remove the cushions (1) as necessary.

[Installation Procedure](#)

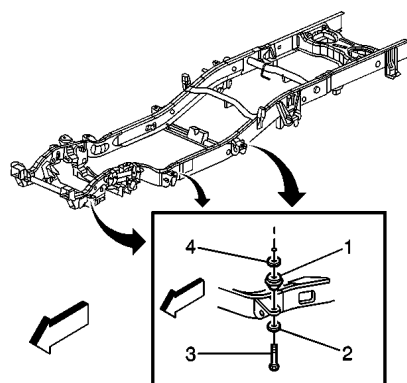

1. Install the cushions (1) as necessary and raise the chassis accordingly.

Notice

Use the correct fastener in the correct location. Replacement fasteners must be the correct part number for that application. Fasteners requiring replacement or fasteners requiring the use of thread locking compound or sealant are identified in the service procedure. Do not use paints, lubricants, or corrosion inhibitors on fasteners or fastener joint surfaces unless specified. These coatings affect fastener torque and joint clamping force and may damage the fastener. Use the correct tightening sequence and specifications when installing fasteners in order to avoid damage to parts and systems.

2. Install the body mount bolts.

Tighten

Tighten the bolts to 85 N·m (63 lb ft).

3. Install the park brake equalizer intermediate cable. Perform the following steps:

- A. Pull rearward on the park brake cable to the original position.
- B. Secure the cable retaining tabs to the frame.
- C. Install the intermediate cable end to the equalizer.
- D. Install the nut to the threaded end of the intermediate cable.

Tighten

Tighten the nut to 4 N·m (31 lb in).

4. Lower the vehicle.
5. Install the master cylinder. Perform the following steps:
 - A. Mount the master cylinder to the brake booster.
 - B. Install the master cylinder mounting nuts.

Tighten

Tighten the nuts to 36 N·m (27 lb ft).

[<- Back](#)[Forward ->](#)

Document ID# 760334
2003 Chevrolet Chevy K Silverado - 4WD

[Print](#)