

<- Back

Forward ->

Document ID# 443455
2001 Chevrolet/Geo Chevy C Silverado - 2WD

Print

Body Control Module Replacement

Removal Procedure

Caution

Before servicing any electrical component, the ignition key must be in the OFF or LOCK position and all electrical loads must be OFF, unless instructed otherwise in these procedures. If a tool or equipment could easily come in contact with a live exposed electrical terminal, also disconnect the negative battery cable. Failure to follow these precautions may cause personal injury and/or damage to the vehicle or its components.

1. Disconnect the negative battery cable(s).

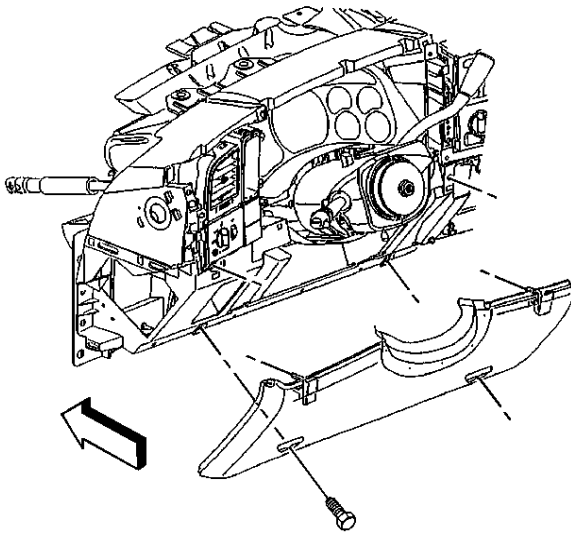

2. Remove the knee bolster. Refer to [Knee Bolster Replacement](#) .

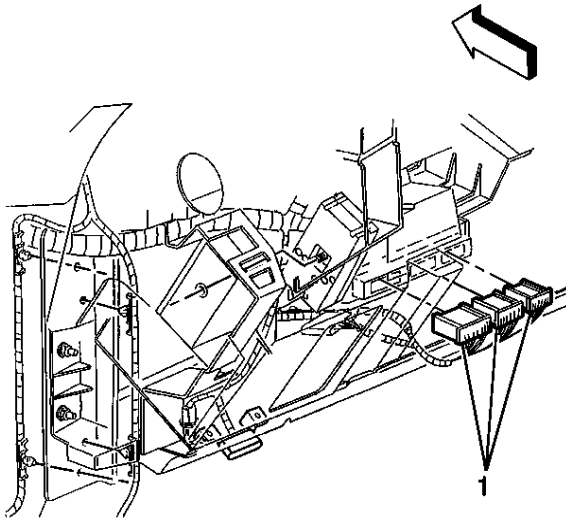

3. Disconnect the brown connector.
4. Disconnect all other connectors (1).
5. Remove the BCM from the sliding bracket.

Installation Procedure

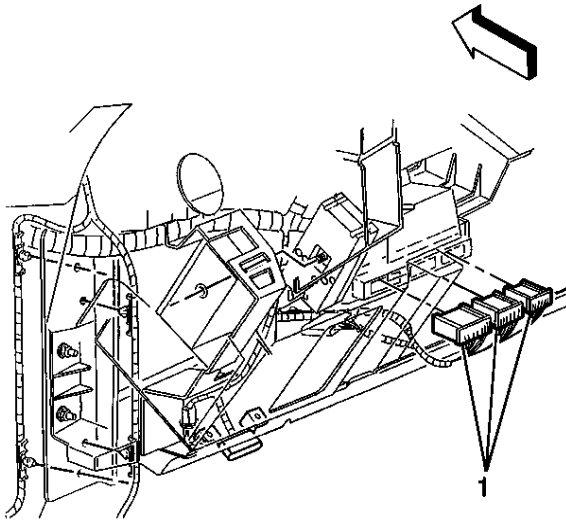

1. Slide the BCM onto the bracket.
2. Connect all the connectors (1) except the brown connector.
3. Connect the brown connector.

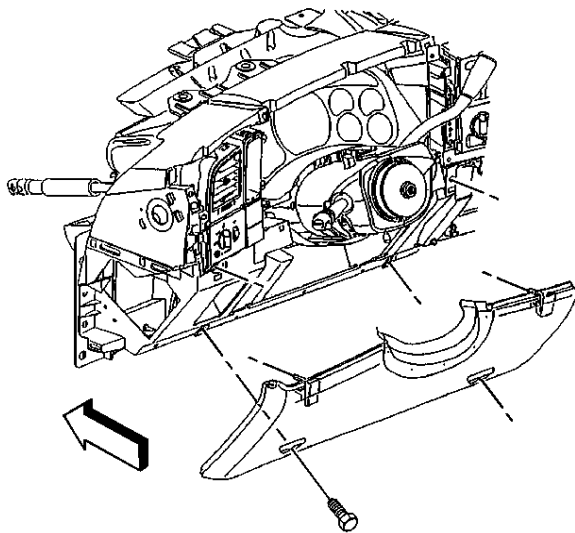

4. Install the knee bolster. Refer to [Knee Bolster Replacement](#) .
5. Connect the negative battery cable(s).
6. Reprogram the BCM. Refer to [Body Control Module \(BCM\) Programming/RPO Configuration](#) .

<- Back

Forward ->

Document ID# 443455
2001 Chevrolet/Geo Chevy C Silverado - 2WD

Print