

#PIT5374: Headlight Performance (BCM Calibration and Bulbs) - (Feb 27, 2015)

Subject: Headlight Performance (BCM Calibration and Bulbs)



Models: 2015 GMC Sierra

2014 GMC Sierra 1500

The following diagnosis might be helpful if the vehicle exhibits the symptom(s) described in this PI.

Condition/Concern

Some customers may comment of poor headlight performance when driving in very dark rural areas. While the headlights meet all Federal Motor Vehicle Safety Standard (FMVSS) requirements and Canada Motor Vehicle Safety Standard (CMVSS) requirements, customers may request better headlight performance for these very dark rural areas.

Recommendation/Instructions

When addressing headlight performance issues, normal diagnostics should be performed first. Verify that all headlights operate, headlight adjustment is correct, and that there is no headlight mounting damage or any issues with the lens itself being damaged/hazy/cloudy/etc. Repair any headlight issues first, and then, if an owner still has a complaint, perform the following repairs:

1. For vehicles built before 12/23/14 at Flint Assembly (11th Vin Digit "F"), 1/13/15 at Silao Assembly (11th Vin Digit "G") or 1/16/15 at Ft. Wayne Assembly (11th Vin Digit "Z"), reprogram the BCM with the latest calibration available in TIS2WEB starting on 1/12/2015. The new BCM calibration will increase the voltage to the headlight bulbs in both the low beam and high beam selections.

Important: All vehicles built after the above dates already have the new BCM calibrations and the BCM reprogramming does NOT need to be performed.

2. Replace both headlight bulbs with updated bulb part number 23342527. **IMPORTANT:** Verify the correct bulb is being installed by confirming the following markings on the bulb:



1. 28432

© 2015 General Motors. All rights reserved.

2. HIR2+30

Important: When installing the new headlight bulbs, do not touch the glass and pay close attention that the bulbs are fully seated into the headlight housing. If the bulb is not properly installed it can lead to an incorrect light pattern. A beam pattern photo with a properly installed bulb is shown below. This photo is of a GMC Sierra Low beam pattern (1 Lamp with opposite lamp blocked) on wall/aiming screen at 25 ft (7.62 m). Each block division is approximately 10.5" (26.67cm)

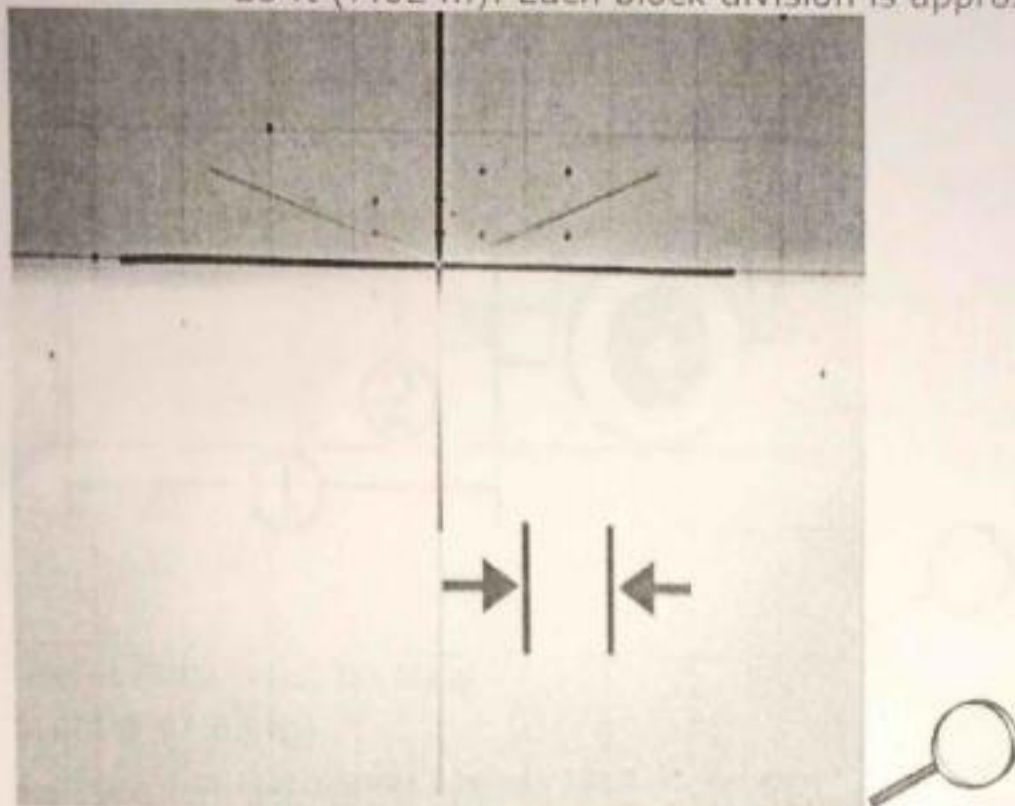

3. After bulb replacement, perform Headlamp Aiming procedure (see below)

Important: The replacement of the bulb along with the calibration change should ONLY be performed at the same time. Doing them as separate service visits may not show the overall desired effect to the customer. Performing these repairs at the same time will show a dramatic improvement.

Headlamp Aiming Procedure

Headlamp aiming is done with the low beam lamps. The high beam lamps will be correctly aimed if the low beam lamps are aimed properly.

Screen Method for Headlamp Aiming (Visual Aim)

The screen method requires an area set up specifically for headlamp aim.

The area should consist of a level surface large enough to allow for a vehicle and an additional 7.62 m (25 ft) as measured from the face of the headlamps to the aiming screen.

The screen should be a wall or other flat surface at least 1.52 m (5 ft) high by 3.66 m (12 ft) wide with a matte white surface well shaded from extraneous light, and 90 degrees to the floor. The screen should have one adjustable horizontal tape.

After the aiming screen has been set up and located:

1. Position the vehicle directly in front of the screen or wall at a distance of 25 feet.
2. Remove any snow, ice or mud from the vehicle.
3. The vehicle should be fully assembled and all other work stopped while the headlamp aiming is being done.
4. The vehicle should contain cargo or be loaded to represent normal vehicle use
5. Tires should be properly inflated.
6. Rock the vehicle to stabilize the suspension.

7. Measure from the floor to either headlamp reference mark.
8. At the screen, measure from the floor and place the horizontal tape at the measured height. This establishes the Horizontal Aiming Line.

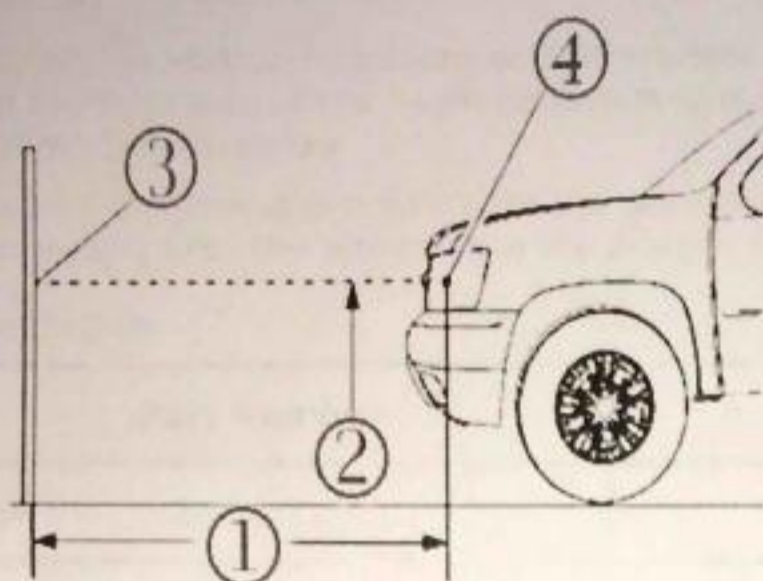

Note: Floor must be level.

1. 25 ft (7.62 m)
 2. Height of Horizontal Aiming Line on screen
 3. Aiming Screen or Wall
 4. Reference mark (small circle) on headlamp lens
9. Turn the headlamps ON.
 10. Block the light from projecting onto the screen from the passenger side headlamp. This will allow the cutoff ("top" of the beam pattern) in the beam pattern from the driver's side to be more pronounced for easier aim verification.
- Important:** DO NOT cover the headlamp, this may cause excessive heat buildup.
11. On this vehicle you will be verifying the vertical aim of the cutoff (top of the beam pattern) on the right side of the "step" in the beam pattern
 12. If the vertical location of the cutoff projected onto the screen or wall differs from the figure below, then an adjustment to the beam pattern location is necessary.

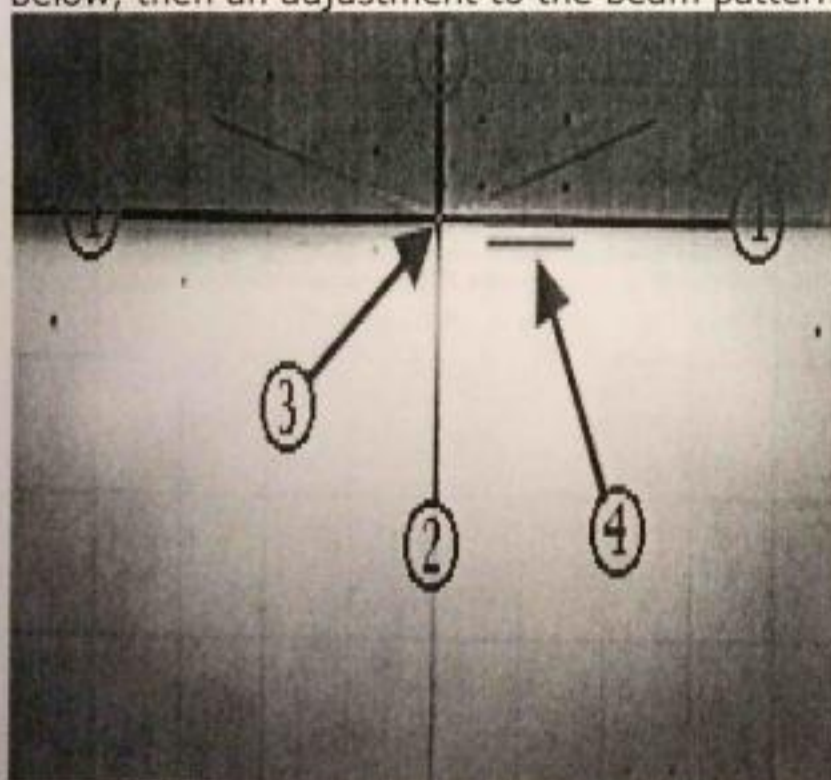

Note: GMC Sierra Low beam pattern (1 Lamp) on wall/aiming screen at 25 ft (7.62 m)

1. Horizontal Aiming Line
 2. Reference line only, Not needed for proper aiming
 3. Step in beam pattern
 4. Top of beam pattern (cutoff line) positioned at the horizontal aiming line +0 / -0.75" (-19mm)
13. Adjust the vertical headlamp aim adjustment screw until the cutoff (top of the beam pattern) on the right side of the beam pattern step is set between the Horizontal Aim Line and 0.75 (19mm) inches below
 14. Repeat the aiming procedure for the passenger's side headlamp while blocking the light from projecting onto the screen from the driver's side headlamp.

Parts Information

Part Number	Description	Qty
23342527	Headlight Bulb	2

Warranty Information

For vehicles repaired under warranty use:

Labor Operation	Description	Labor Time
2810215	Reprogram BCM	Use Published Labor Operation Time

Labor Operation	Description	Labor Time
2080428*	Replaced Both Headlamps Bulbs And Aim Headlamps	0.8 hr
* This is an unique labor operation for bulletin use only. This will not be published in the Labor Time Guide.		

Please follow this diagnostic or repair process thoroughly and complete each step. If the condition exhibited is resolved without completing every step, the remaining steps do not need to be performed.

GM bulletins are intended for use by professional technicians, NOT a "do-it-yourselfer". They are written to inform these technicians of conditions that may occur on some vehicles, or to provide information that could assist in the proper service of a vehicle. Properly trained technicians have the equipment, tools, safety instructions, and know-how to do a job properly and safely. If a condition is described, DO NOT assume that the bulletin applies to your vehicle, or that your vehicle will have that condition. See your GM dealer for information on whether your vehicle may benefit from the information.



WE SUPPORT
VOLUNTARY
TECHNICIAN
CERTIFICATION